



## Type J21K Differential Pressure Switch



UNITED ELECTRIC  
CONTROLS

## Installation and Maintenance Instructions

Please read all instructional literature carefully and thoroughly before starting. Refer to the final page for the listing of Recommended Practices, Liabilities and Warranties.

### GENERAL



BEFORE INSTALLING, CHECK THE SENSOR MODEL SELECTED FOR COMPATIBILITY TO THE PROCESS MEDIA IN CONTACT WITH THE SENSOR AND WETTED PARTS.

The J21K Differential Pressure Switch utilizes opposing metal bellows to detect pressure differences between two pressure sources. When the pressure at the high port exceeds the pressure at the low port by a pre-determined amount (set point), the mechanism operates a single snap-action electrical switch. Control set point may be adjusted by turning the internal adjustment hex screw (see Part II - Adjustments).



PROOF PRESSURE\* LIMITS STATED IN THE LITERATURE AND ON NAMEPLATES MUST NEVER BE EXCEEDED, EVEN BY SURGES IN THE SYSTEM. OCCASIONAL OPERATION OF UNIT UP TO PROOF PRESSURE IS ACCEPTABLE (E.G., START-UP, TESTING). CONTINUOUS OPERATION SHOULD NOT EXCEED THE DESIGNATED OVER RANGE PRESSURE.

#### \*Proof Pressure

The maximum pressure to which a pressure sensor may be occasionally subjected, which causes no permanent damage (e.g., start-up testing). The unit may require adjustment.



THESE PRODUCTS DO NOT HAVE ANY FIELD REPLACEABLE PARTS.

## Part I - Installation

#### Tools Needed

- Adjustable wrenches (2)
- Flat blade screwdriver

### MOUNTING



INSTALL UNIT WHERE SHOCK, VIBRATION AND TEMPERATURE FLUCTUATIONS ARE MINIMAL. MOUNT UNIT SO THAT MOISTURE IS PREVENTED FROM ENTERING THE ENCLOSURE. DO NOT MOUNT UNIT IN AMBIENT TEMPERATURES EXCEEDING PUBLISHED LIMITS.

Surface mount in any position via two mounting ears. Never turn this unit by grasping enclosure. Always hold a wrench on the bellows housing (or fitting) when connecting pressure joints.

### WIRING



DISCONNECT ALL SUPPLY CIRCUITS BEFORE WIRING UNIT. WIRE UNITS ACCORDING TO NATIONAL AND LOCAL ELECTRICAL CODES. MAXIMUM RECOMMENDED WIRE SIZE IS 14 AWG.



ELECTRICAL RATINGS STATED IN LITERATURE AND ON NAMEPLATES MUST NOT BE EXCEEDED, OVERLOAD ON A SWITCH CAN CAUSE FAILURE ON THE FIRST CYCLE.

Remove the four (4) screws retaining the cover and gasket. Remove cover. Connect conduit to the enclosure using a conduit fitting that is suitable for your installation. A watertight conduit fitting (option M900 or equivalent) must be used for NEMA 4 protection. Wire directly to the switch terminals in accordance with local and national electrical codes. Bring the wires up to the terminals from the rear of the enclosure to prevent interference with the mechanism.

## Part II - Adjustments

#### Tools Needed

- 5/16" open end wrench

For set point adjustment and re-calibration, connect the "High" pressure port to a calibrated pressure source.

Set point adjustment is achieved by varying the gap between the mechanical actuator and the plunger on the electrical switch

#### J21K

To raise the differential pressure setting, turn the 5/16" hex head screw out (clockwise).

To lower the differential pressure setting, turn the 5/16" hex head screw in (counter-clockwise).

# Dimensions

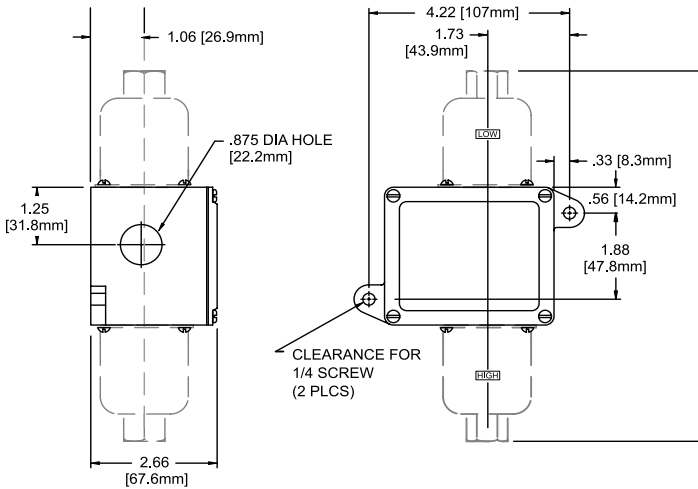

### Dimension A

Models	Inches	mm	NPT
127-150	8.06	204.7	1/4
S127B	8.94	227.10	1/2
S140B-S150B	8.86	225.0	1/2
232	6.53	165.9	1/4
254	6.50	165.1	1/4
357	6.88	174.8	1/4

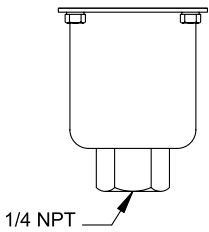

Models 127-150

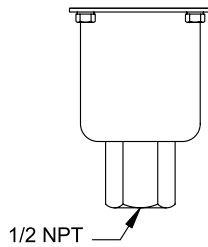

Models S127B-S150B

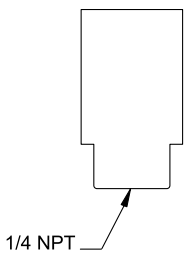

Models 232

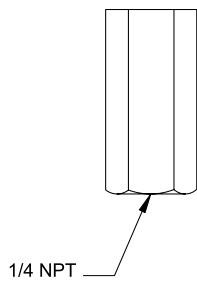

Models 254

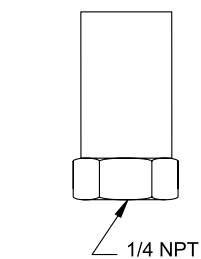

Models 357

## RECOMMENDED PRACTICES AND WARNINGS

United Electric Controls Company recommends careful consideration of the following factors when specifying and installing UE pressure and temperature units. Before installing a unit, the Installation and Maintenance instructions provided with unit must be read and understood.

- To avoid damaging unit, proof pressure and maximum temperature limits stated in literature and on nameplates must never be exceeded, even by surges in the system. Operation of the unit up to maximum pressure or temperature is acceptable on a limited basis (e.g., start-up, testing) but continuous operation must be restricted to the designated adjustable range. Excessive cycling at maximum pressure or temperature limits could reduce sensor life.
- A back-up unit is necessary for applications where damage to a primary unit could endanger life, limb or property. A high or low limit switch is necessary for applications where a dangerous runaway condition could result.
- The adjustable range must be selected so that incorrect, inadvertent or malicious setting at any range point cannot result in an unsafe system condition.
- Install unit where shock, vibration and ambient temperature fluctuations will not damage unit or affect operation. When applicable, orient unit so that moisture does not enter the enclosure via the electrical connection. When appropriate, this entry point should be sealed to prevent moisture entry.
- Unit must not be altered or modified after shipment. Consult UE if modification is necessary.
- Monitor operation to observe warning signs of possible damage to unit, such as drift in set point or faulty display. Check unit immediately.
- Preventative maintenance and periodic testing is necessary for critical applications where damage could endanger property or personnel.
- Electrical ratings stated in literature and on nameplate must not be exceeded. Overload on a switch can cause damage, even on the first cycle. Wire unit according to local and national electrical codes, using wire size recommended in installation sheet.
- Do not mount unit in ambient temp. exceeding published limits.

## LIMITED WARRANTY

Seller warrants that the product hereby purchased is, upon delivery, free from defects in material and workmanship and that any such product which is found to be defective in such workmanship or material will be repaired or replaced by Seller (Ex-works, Factory, Watertown, Massachusetts, INCOTERMS); provided, however, that this warranty applies only to equipment found to be so defective within a period of 24 months from the date of manufacture by the Seller. Seller shall not be obligated under this warranty for alleged defects which examination discloses are due to tampering, misuse, neglect, improper storage, and in any case where products are disassembled by anyone other than authorized Seller's representatives. EXCEPT FOR THE LIMITED WARRANTY OF REPAIR AND REPLACEMENT STATED ABOVE, SELLER DISCLAIMS ALL WARRANTIES WHATSOEVER WITH RESPECT TO THE PRODUCT, INCLUDING ALL IMPLIED WARRANTIES OF MERCHANTABILITY OR FITNESS FOR ANY PARTICULAR PURPOSE.

## LIMITATION OF SELLER'S LIABILITY

Seller's liability to Buyer for any loss or claim, including liability incurred in connection with (i) breach of any warranty whatsoever, expressed or implied, (ii) a breach of contract, (iii) a negligent act or acts (or negligent failure to act) committed by Seller, or (iv) an act for which strict liability will be inputted to seller, is limited to the "limited warranty" of repair and/or replacement as so stated in our warranty of product. In no event shall the Seller be liable for any special, indirect, consequential or other damages of a like general nature, including, without limitation, loss of profits or production, or loss or expenses of any nature incurred by the buyer or any third party.

UE specifications subject to change without notice.



UNITED ELECTRIC  
CONTROLS

180 Dexter Avenue, P.O. Box 9143  
Watertown, MA 02471-9143 USA  
Telephone: 617 926-1000 Fax: 617 926-2568  
<http://www.ueonline.com>